

**Built To Order**

**4' x 4' Units  
Featuring Motor Blower Assemblies  
and HEPA Filters Replaceable  
From Roomside**

SAM 44 GS Fan Filter Units feature HEPA or ULPA grade final filters replaceable from roomside.

All standard SAM 44 Fan Filter Units include HEPA or ULPA grade filters, seismic clip suspension points, safety switch which disables the unit while servicing, and solid state variable speed control with RFI suppression, allowing the airflow to be fine tuned.

Removing the polystyrene eggcrate grille with an anodized aluminum frame, permits removal of the final filter without removing the unit from the ceiling. Optional perforated stainless steel or aluminum grilles are available.

Removable from roomside motor blower assemblies are chosen after consulting with our sales and engineering departments. Voltages range from 115 to 277 volt single phase, 50/60hz or 208 to 480 volt, three phase.

Choices for final filters are Gel Seal HEPA grade 99.99% eff. @ 0.3 micron or ULPA grade 99.9995% eff. @ 0.12 micron or larger.

Final filters are protected with a white epoxy diamond pattern grille and are tested according to accepted procedures as described by the Institute of Environmental Sciences (IEST) and/or ISO standards.

Consult with one of our cleanroom experts in your area, or call the factory for more information.

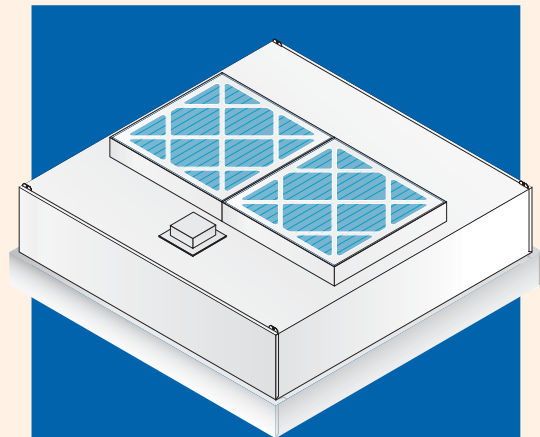

**Motor Blowers Selected to Meet  
Your Performance Specifications**

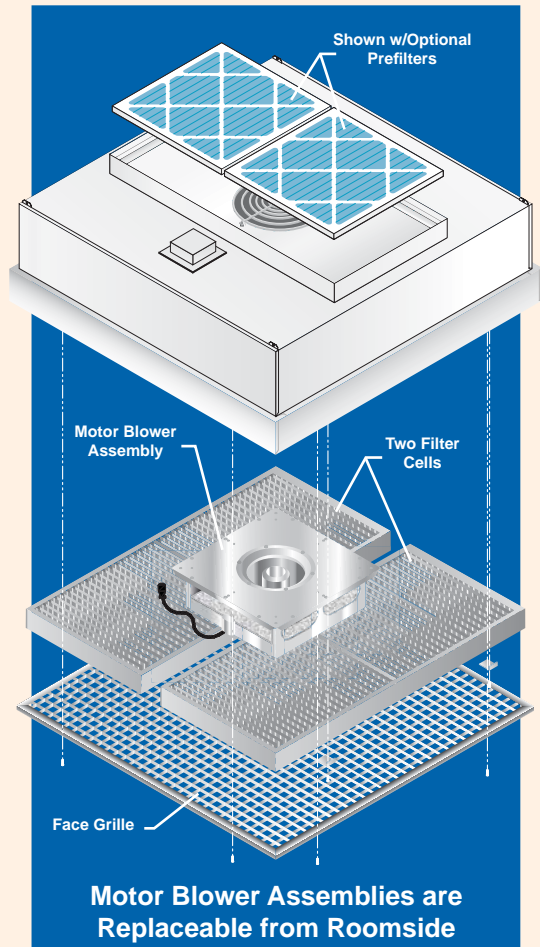

**Motor Blower Assemblies are  
Replaceable from Roomside**

SAM is a registered trademark owned by Clean Rooms International

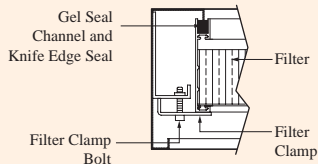
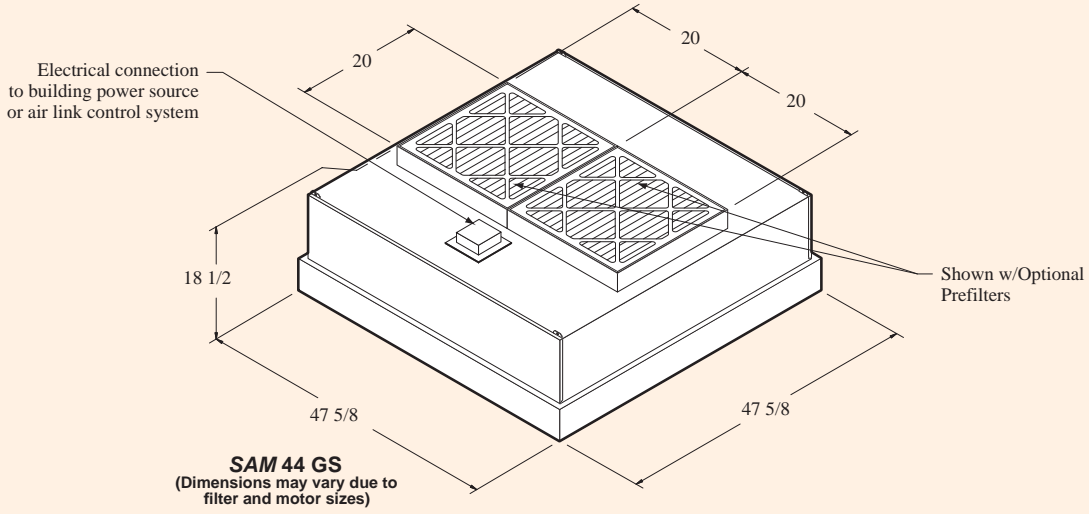

**Filter Clamp Detail**  
Typical of a Unit with One Filter

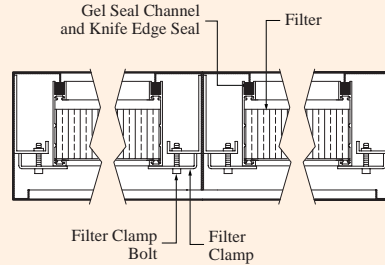

**Gel Seal Style Filter Clamp Detail**  
Typical of a Unit with Two Filters

**HEPA Filter Data:** HEPA Filters with upstream gel channel are designed for 90 FPM average face velocity @ initial 0.47 w.g. and has a rated efficiency of 99.99% @ 0.3 micron or larger. An access port with removable plug is located in the center of the filter element face for introducing an upstream challenge or measuring static pressure.

### Ordering Information

Mfg. Code	Model or Description	Style	Size	Motor	Voltage	Hz	Watts	FLA	Weight
12399	SAM 44 GS	GS	4 x 4	*	*	*	*	*	*

\* Motor Blower Selection will determine these items.

### Replacement Filters

302200	Units with two filters: Gel Seal Style HEPA Filter, 99.99% eff. @ 0.3 micron
302203	Units with two filters: Gel Seal Style ULPA Filter, 99.9995% eff. @ 0.12 micron
	Units with single filters are built to order. Consult with CRI factory.