

Duct Collar Adaptor

Duct Collar Adaptors	
Model No.	Description
19950	10" Duct Collar Adaptor with galvanized finish
19951	12" Duct Collar Adaptor with galvanized finish

* No Prefilter is used
 * Two required for SAM 26 models

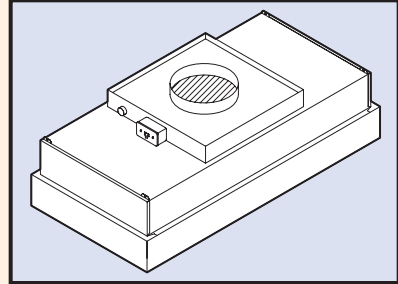

Top Load Duct Collar Adaptors (Allows the Prefilter to be changed from the top)	
Model No.	Description
19955	Top Load Adaptor w/10" Duct Collar Adaptor with galvanized finish
19956	Top Load Adaptor w/12" Duct Collar Adaptor with galvanized finish

* Two required for SAM 26 models
 * Add 1-1/2" to total height of unit

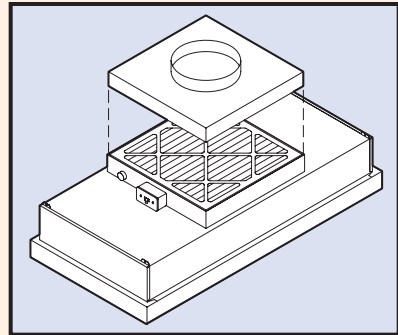

Side Load Prefilter w/Duct Collar (Allows the Prefilter to be changed from the side when space is limited)	
Model No.	Description
19952	Side Load Prefilter Frame w/10" Duct Collar Adaptor with galvanized finish
19953	Side Load Prefilter Frame w/12" Duct Collar Adaptor with galvanized finish

* Two required for SAM 26 models
 * Add 1-1/2" to total height of unit

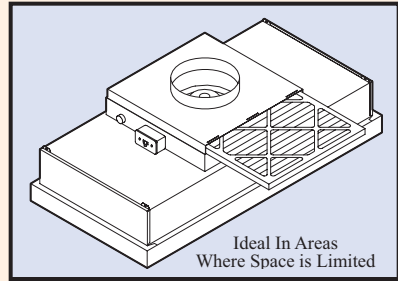

Air Conditioning Mixing Box (Allows Conditioned Air Connection to SAM Unit)	
Model No.	Description
19958	With 10" Duct Collar
19959	With 12" Duct Collar

* For Open Plenum Systems
 * Galvanized finish and White Powdercoat finish available

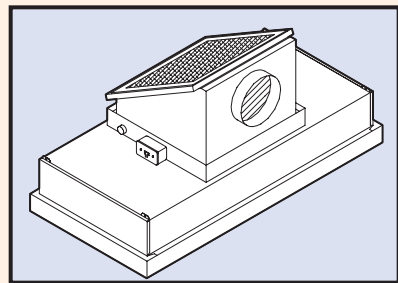

Mixing Box (Allows Conditioned Air Connection to SAM Unit)	
Model No.	Description
19947	With 10" Duct Collar
19948	With 12" Duct Collar

* Galvanized finish and White Powdercoat finish available

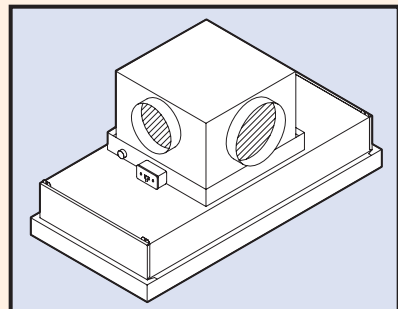

NOTE: Use of Duct collar adaptors, and mixing boxes negates UL listing.