

## Ideal for Pharmaceutical Companies

### Gel Seal Style HEPA or ULPA Filter Replaceable From Roomside

SAM MicroSound GS fan filter units are ideal for pharmaceutical companies, manufacturers of medical devices and companies in highly regulated industries. The SAM GS units feature a gel channel on the upstream side of the final filter which provides a leak-free seal between the filter and the housing.

SAM MicroSound GS units feature a HEPA or ULPA filter replaceable from roomside while the filter housing remains in place.

Housings are fabricated from steel with a white powdercoat finish and include seismic clip suspension points.

The energy efficient N310 motor blower is a low watt backward curved impeller, single phase, permanent split capacitor type motor blower assembly with thermal overload protection. Units are available in 115V (60 Hz), 208-230V (50/60 Hz) and 277V (60 Hz).

SAM MicroSound Fan Filter Units include a 99.99% efficient HEPA filter, 30% ASHRAE pleated type prefilter, seismic clip suspension points, safety switch which disables the unit while servicing, and solid state variable speed control with RFI suppression, allowing the airflow to be fine tuned.

Final filters are protected with a white epoxy diamond pattern grille and are tested according to accepted procedures as described by the Institute of Environmental Sciences (IEST) and/or ISO standards. The standard HEPA filter is 99.99% eff. and an ULPA grade 99.9995% eff. filter is available as an option.

A polystyrene eggcrate grille in an anodized aluminum frame is hinged to open, permitting removal of the filter without removing the unit from the ceiling. Optional perforated stainless steel or aluminum grilles are available.

Other popular options include an 8' power cord (110 Volt only), 99.9995% eff. ULPA grade final filter, UL 900 Class 1 filters and duct collar adapters are available as options. Refer to the back of this section for more options and accessories.

For horizontal flow applications consult with one of our cleanroom experts in your area, or call the factory for more information.

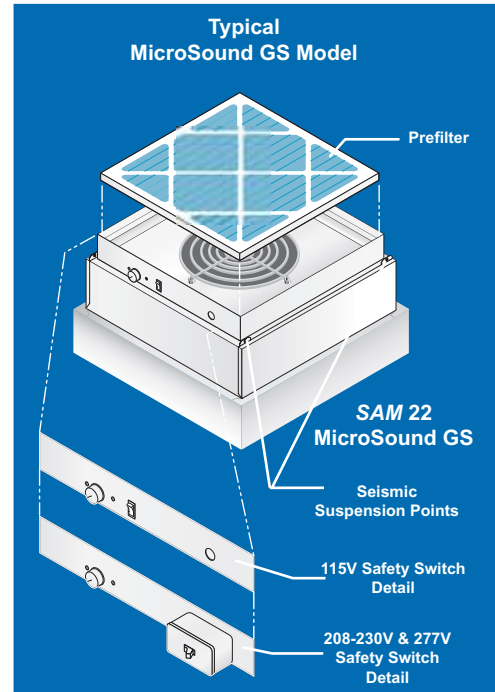

- **Energy Efficient Motor:** Operating Amps Low As .6 For 277 Volt And 1.8 For 115 Volt
- **Safety Switch:** Disables Unit While Servicing
- **Variable Speed Control:** Allows Air Flow To Be Fine Tuned For Room Requirements

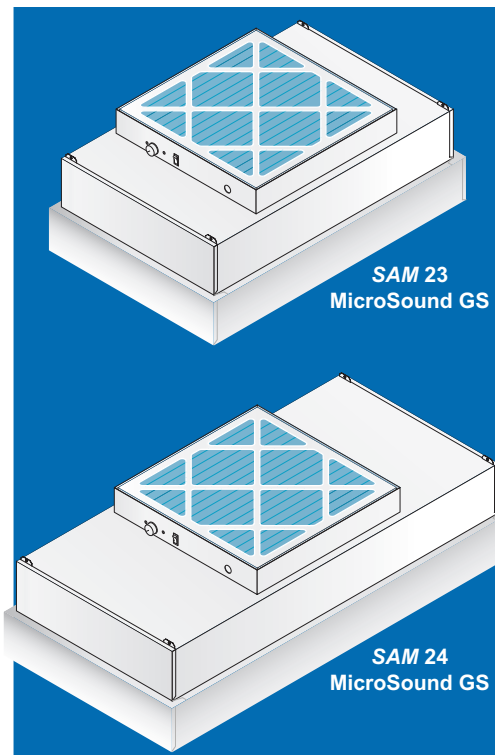

SAM is a registered trademark owned by Clean Rooms International

# Data & Specifications for SAM<sup>®</sup> MicroSound GS

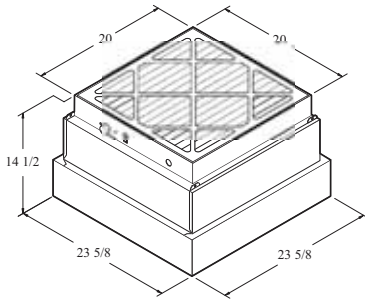

**SAM 22 MicroSound GS**

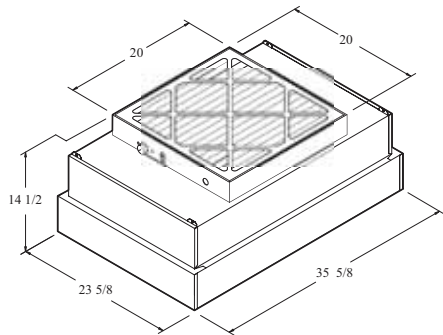

**SAM 23 MicroSound GS**

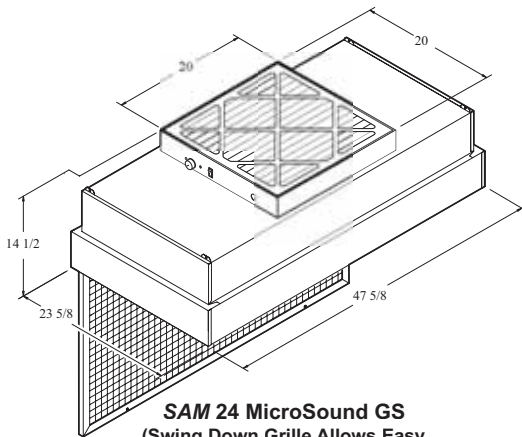

**SAM 24 MicroSound GS**  
(Swing Down Grille Allows Easy Access To Filter)

**GS Style Filter Data:** The HEPA Filter is designed for 90 FPM average face velocity @ initial 0.47 w.g. and has a rated efficiency of 99.99% @ 0.3 micron or larger.

An anodized aluminum frame holds the 53mm media which is protected by a diamond pattern white epoxy coated steel grille. Final filters are replaceable from roomside.

**Access Port:** This port is located in the center of the filter element face and is used for introducing an upstream challenge or measuring static pressure.

**Standard Ceiling Size:** All 2' x 4' models are designed to fit a nominal 2' x 4' ceiling grid with a 22.5" x 46.5" standard opening.

**Air Flow:** Airflow ranges from 340 to 640 CFM for a 2 x 4 unit and 220 to 340 CFM for a 2 x 2 unit. At 90 FPM, CFM is nominal 510 on a 2 x 4 and 220 on a 2 x 2 unit respectively. Airflow for units running at 50 Hz will be about 20% less.

**Sound Level:** At average face velocity of 90 FPM measured 30" from face of filter, sound level is approximately 54 dba with less than 45 dba ambient sound level. Field conditions and method of testing could produce different results.

**Popular Options:** Refer to next page for a list of popular options.

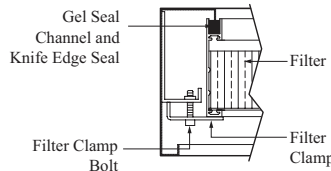

**Filter Clamp Detail**

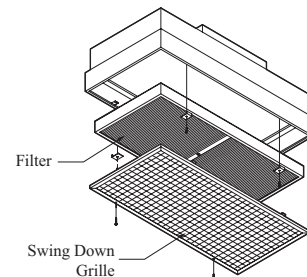

**Exploded View**

Motor Data					
Motor	Voltage	Hz	Watts	Running Amps	Start-Up Amps
N310	115	60	185	1.6	4.1
N310	208-230	50/60	165	0.8-0.7 <sup>(1)</sup>	1.5 <sup>(2)</sup>
N310	277	60	165	.6	1.5
(1) Running amps will be less on 50Hz					
(2) Line voltage can affect actual start-up amperage					

Replacement Filters	
Mfg. Code	Description
302201	2 x 2 GS Style HEPA Filter, 99.99% eff. @ 0.3 micron
302204	2 x 2 GS Style ULPA Filter, 99.9995% eff. @ 0.12 micron
302214	2 x 3 GS Style HEPA Filter, 99.99% eff. @ 0.3 micron
302215	2 x 3 GS Style ULPA Filter, 99.9995% eff. @ 0.12 micron
302200	2 x 4 GS Style HEPA Filter, 99.99% eff. @ 0.3 micron
302203	2 x 4 GS Style ULPA Filter, 99.9995% eff. @ 0.12 micron
302190	Prefilter 20" x 20" x 1", 30% ASHRAE efficient, pleated type

# Ordering Information for SAM<sup>®</sup> MicroSound GS

<b>Base Model (Ordering Information)</b>								
Mfg. Code	Model or Description	Style	Size	Voltage	Motor	Variable Speed Control	HEPA Filter	Weight
12800	SAM 22 MS GS	GS	2 x 2	115	N310	703084	302201	68 lbs. (30.9 kg.)
12801	SAM 22 MS GS	GS	2 x 2	208-230	N310	703912	302201	68 lbs. (30.9 kg.)
12802	SAM 22 MS GS	GS	2 x 2	277	N310	703915	302201	68 lbs. (30.9 kg.)
12803	SAM 23 MS GS	GS	2 x 3	115	N310	703084	302214	76 lbs. (38.2 kg.)
12804	SAM 23 MS GS	GS	2 x 3	277	N310	703915	302214	76 lbs. (38.2 kg.)
12805	SAM 24 MS GS	GS	2 x 4	115	N310	703084	302200	84 lbs. (38.2 kg.)
12806	SAM 24 MS GS	GS	2 x 4	208-230	N310	703912	302200	84 lbs. (38.2 kg.)
12807	SAM 24 MS GS	GS	2 x 4	277	N310	703915	302200	84 lbs. (38.2 kg.)

\* Prefilter and Safety Switch are Standard on all Models

**Popular Options:** (Please choose from the following part numbers when ordering options)

**Final Filters:**

- 302204 2 x 2 GS ULPA Filter 99.9995% eff.
- 302214 2 x 3 GS ULPA Filter 99.9995% eff.
- 302203 2 x 4 GS ULPA Filter 99.9995% eff.
- 000000 2 x 2 GS HEPA UL 900 Class 1
- 000000 2 x 4 GS HEPA UL 900 Class 1
- 000000 2 x 4 GS ULPA UL 900 Class 1
- 000000 2 x 2 GS ULPA UL 900 Class 1

**Prefilters:**

- 309802 Super Clean Prefilter  
Suitable for Class 1-100

**Duct Collar Adapters:**

- 19950 10" Duct Collar Adapter
- 19951 12" Duct Collar Adapter
- 19952 Side Load with 10" Duct Collar
- 19953 Side Load with 12" Duct Collar
- 19955 10" Top Load Duct Collar Adapter
- 19956 12" Top Load Duct Collar Adapter

**Grilles 1/8" Round Perforated:** (40% open area)

- 19506 2 x 2 CRF Anodized Alum. Grille and Frame
- 19507 2 x 4 CRF Anodized Alum. Grille and Frame
- 19508 2 x 2 CRF Round Perf w/1/8" Holes, White Powdercoated Grille and Frame
- 19509 2 x 4 CRF Round Perf w/1/8" Holes, White Powdercoated Grille and Frame
- 19511 2 x 4 CRF S.S. Rnd. Perf Grille w/Anodized Alum. Frame
- 19512 2 x 2 CRF S.S. Rnd. Perf Grille w/Anodized Alum. Frame
- 19514 2 x 4 CRF S.S. Perf Grille w/S.S Frame

**Air Conditioning Mixing Box:**

- 19958 Slanted Top with 10" Duct Collar
- 19959 Slanted Top with 12" Duct Collar
- 19947 Square with (2) 10" Duct Collars
- 19948 Square with (2) 12" Duct Collars

**Roomside Variable Speed Control:**

- 19933 CRF Style 110-120 Volt
- 19934 CRF Style 208-230 Volt
- 19935 CRF Style 277 Volt

**Pilot Light:**

- 19702 NCR Style Red Pilot Light 110-120 Volt Only (Light Indicates Power to Motor Only)
- 19703 NCR Style Red Pilot Light w/Pressure Switch 110-120 Volt Only (Light Indicates Power to Motor Only)

**Radial Diffuser Grille:**

- 19300 2 x 2 Radial Diffuser Grille
- 19301 2 x 4 Radial Diffuser Grille

**Miscellaneous:**

- 703902 8' Power Cord 110-120V Only
- 603322 Gasket on Downstream Edge of Unit
- Magnehelic Gage: Refer to the Back of this Section
- Static Control: Refer to the Back of this Section

Comments:

---



---



---



---

*NOTE: Duct collar adapters, air conditioning boxes, pilot lights and adding other electrical components negates UL listing.*

*For more information and illustrations please refer to the back of this section*